

UNIDIRECTIONAL "LUG" Knife Gate Valve

- Unidirectional LUG-design knife gate valve.
- Monobloc cast body with interior slides for optimum movement of the through conduit during operation and seal wedges.
- Provides high flow rates with low pressure drop.
- Various seal and packing materials available.
- Face-to-face distance in accordance with **C.M.O.** standard.
- An arrow is marked on the body indicating the flow direction.

General applications:

This knife gate valve is suitable for liquids that contain a maximum of 5% suspended solids. If used for solids, we recommend installing with the body are which indicates the contrary flow direction. Designed for applications such as:

- | | | |
|-------------------|----------|-----------------|
| -Paper Industry | -Mining | -Silo emptying |
| -Chemical plants | -Pumping | - Food industry |
| -Sewage treatment | | - Drying plants |

Sizes: DN50 to DN2000 (larger sizes on request).

Working (ΔP):

- | | |
|--------------------------------------|--|
| -DN50 to DN150: 10kg/cm ² | -DN200: 8kg/cm ² |
| -DN250 to DN300: 6kg/cm ² | -DN350 to DN400: 5 kg/cm ² |
| -DN450 to DN600: 3kg/cm ² | -DN700 to DN1400: 2 kg/cm ² |

- The mentioned working pressures are just valid for the pressures applied on the direction of the arrow market on the body. As the valves is designed with gate support guides, the valves are able to support a 30% of these pressures from the opposite direction without any damage on them. In these cases, the valves are not a 100% water tight. To obtain a total water tightness in these conditions, it is necessary to incorporate additional supports.

Standard flanges: DIN PN10 and ANSI B16.5 (class 150)

Other common flanges: DIN PN 16	JIS standard	Australian Standard
DIN PN 6	DIN PN25	British Standard

Directives:

- Machinery Directive: **DIR 2006/42/EC (MACHINERY)**
- Pressure Equipment Directive: **DIR 97/23/EC (PED) ART.3, P.3**
- Potentially Explosive Atmospheres Directive (optional): **DIR 94/9/EC (ATEX) CAT.3 ZONE 2 and 22 GD** , for information on categories and zones please contact **C.M.O.** Technical-Sales Department.

Quality dossier:

- All valves are tested hydrostatically at **C.M.O.** and material and test certificates can be provided.
- Body test = working pressure x 1.5.
- Seal test = working pressure x 1.1.

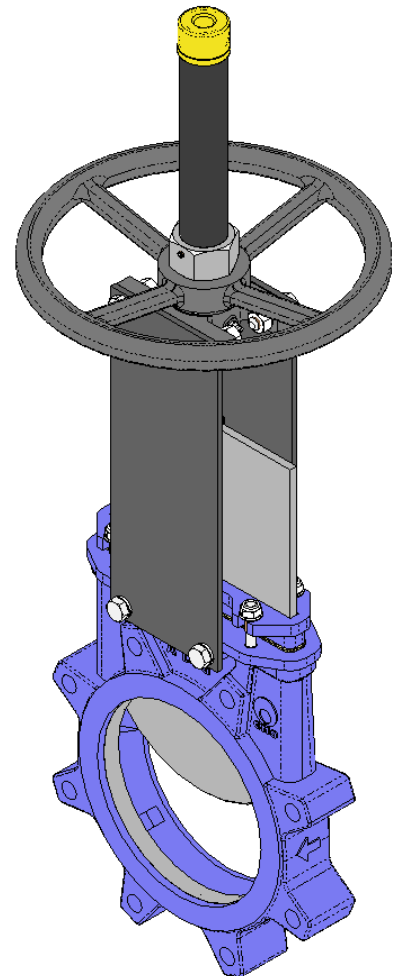

fig. 1

KNIFE GATE VALVES

A LUG SERIES

Advantages of C.M.O. "A LUG Model"

When a knife gate valve remains open for long periods of time and the body's internal walls are parallel a very large torque is required to close it. Model **A LUG's** body is cone-shaped inside, providing greater space. This way, when the valve is shut-off the solids stored inside it can be easily released.

This valve is defined as unidirectional and in this type of valves of other suppliers there is the risk of the through conduit bending due to the existence of counterpressure. This cannot happen with the **C.M.O.** valve because it contains internal slides that support the through conduit and allow it to work under counter-pressure of 30% of the maximum working pressure, without the through conduit becoming deformed.

The stem protection hood is independent from the handwheel securing nut, this means the hood can be disassembled without the need to release the handwheel. This advantage allows regular maintenance operations to be performed, such as lubricating the stem, etc.

The stem on the **C.M.O.** valve is made of 18/8 stainless steel. This is another added advantage, as some manufacturers produce it with 13% chrome and it gets rusty very quickly.

The handwheel is made of GJS-500 nodular cast iron. Some manufacturers produce them in normal cast iron which can lead to breakages in the event of very high operating torque or knocks. The yoke has a compact design with the bronze actuator nut protected in a sealed and lubricated box. This makes it possible to move the valve with a key, even without the handwheel (in other manufacturers' products this is not possible).

The pneumatic actuator's upper and lower covers are made of GJS-400 nodular cast iron, making them highly shock resistant. This characteristic is essential in pneumatic actuators.

The pneumatic cylinder's seals are commercial products and can be purchased worldwide. This means it is not necessary to contact **C.M.O.** every time a seal is required.

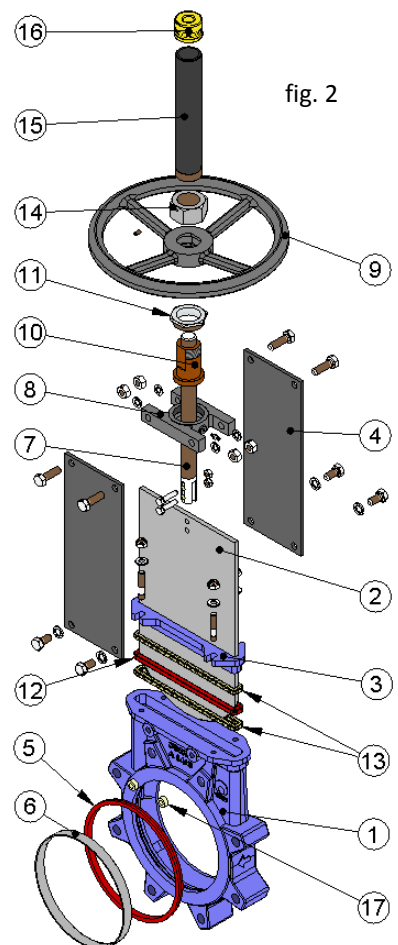

STANDARD COMPONENTS LIST		
COMPONENT	CAST IRON VERSION	STAINLESS STEEL VERSION
1- Body	GJL-250	CF8M
2- Through conduit	AISI304	AISI316
3- Packing gland	GJS-500	CF8M
4- Support plates	STEEL	STEEL
5- Sealing joint	EPDM	EPDM
6. Ring	AISI316	AISI316
7- Stem	AISI303	AISI303
8- Yoke	GJS-500	GJS-500
9- Handwheel	GJS-500	GJS-500
10- Stem nut	BRONZE	BRONZE
11- Stopper Nut	STEEL	STEEL
12- Packing seal.	EPDM	EPDM
13- Gasket	SYNT + PTFE	SYNT + PTFE
14- Hood nut	5.6 ZINC	5.6 ZINC
15- Hood	STEEL	STEEL
16- Protection cap	PLASTIC	PLASTIC
17- Slides	RCH1000	RCH1000

table 1

C.M.O.

Amategui Aldea 142, 20400 Txarama-Tolosa (SPAIN)

TEC-A LUG.EN08

Tel. Nacional: 902.40.80.50 Fax: 902.40.80.51 / Tel. Internacional: 34.943.67.33.99 Fax: 34.943.67.24.40

cmo@cmo.es <http://www.cmo.es>

page. 2

DESIGN CHARACTERISTICS

1- BODY

Monobloc "LUG" cast body with interior slides for optimum movement of the through conduit and wedges for improved sealtightness.

For diameters greater than DN1200 the body is machine-welded with the necessary reinforcements to resist the maximum working pressure.

Designed with full passage to provide large flows with small losses of load.

The body's internal design prevents any build-up of solids in the seal area.

The standard manufacturing materials are GJL-250 cast iron and CF8M stainless steel. Other materials, such as GJS-500 nodular cast iron, A216WCB carbon steel and stainless steel alloys (AISI316Ti, Duplex, 254SMO, Uranus B6...) are available on request. As standard, iron or carbon steel valves are painted with an anti-corrosive protection of 80 microns of EPOXY (colour RAL 5015). Other types of anti-corrosive protections are available on request.

2- THROUGH CONDUIT

The standard manufacturing materials are AISI304 stainless steel in valves with carbon steel body and AISI316 stainless steel in valves with CF8M body. Other materials or combinations can be supplied to order.

The through conduit is polished on both sides to provide a smooth contact surface with the resilient seal. At the same time, the through conduit is rounded to prevent the seal from being cut. Different degrees of polishing, anti-abrasion treatments and modifications are available to adapt the valves to the customer's requirements.

3- SEAT: (sealtight)

Six types of seats are available according to the working application:

-**Seat 1:** Metal / metal seal. This type of seal does not include any kind of resilient seal and the estimated leakage (considering water as the test fluid) is 1.5% of the pipe flow.

-**Seat 2:** Standard metal/rubber seal. This type of seal includes a resilient seal which is fixed to the inside of the body via an AISI316 stainless steel retaining ring.

-**Seat 3:** Metal / rubber seal with reinforced ring. This type of seal includes a resilient seal which is fixed to the inside of the body by way of a reinforced ring with two functions (to protect the valve from abrasion and clean the through conduit when working with solids that can stick to the through conduit).

- **Seats 4, 5 and 6:** The same as seats 1, 2 and 3 but including a deflector. The deflector is an O-ring located at the valve input with two functions: firstly to protect the valve from abrasion and secondly to guide the flow to the centre of the valve.

***Note:** Three materials are available for the reinforced ring and the deflector: Steel CA-15, CF8M and Ni-hard.

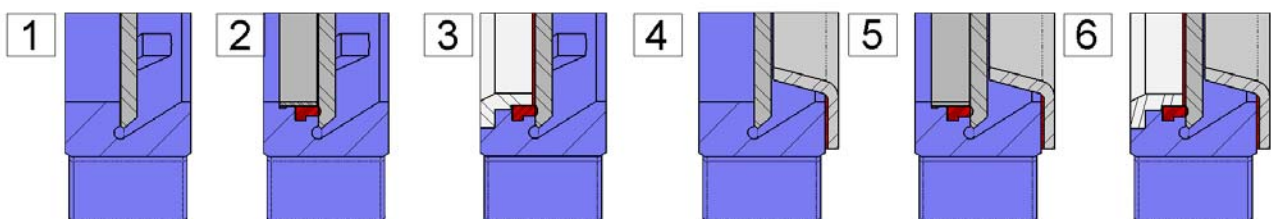

fig. 3

C.M.O.

Amategui Aldea 142, 20400 Txarama-Tolosa (SPAIN)

TEC-A LUG.EN08

Tel. Nacional: 902.40.80.50 Fax: 902.40.80.51 / Tel. Internacional: 34.943.67.33.99 Fax: 34.943.67.24.40

cmo@cmo.es <http://www.cmo.es>

page. 3

KNIFE GATE VALVES

A LUG SERIES

Sealtight materials

EPDM

This is the standard resilient seat fitted on **C.M.O.** valves. It can be used in many applications, however, it is generally used for water and products diluted in water at temperatures no higher than 90°C*. It can also be used with abrasive products and it provides the valve with 100% watertight integrity.

NITRILE

It is used in fluids containing fats or oils at temperatures no higher than 90°C*. It provides the valve with 100% watertight integrity.

VITON

Suitable for corrosive applications and continuous high temperatures of up to 190°C and peaks of 210°C. It provides the valve with 100% watertight integrity.

SILICONE

Mainly used in the food industry and for pharmaceutical products with temperatures no higher than 200°C. It provides the valve with 100% watertight integrity.

PTFE

Suitable for corrosive applications and pH between 2 and 12. Does not provide the valve with 100% watertight integrity. Estimated leakage: 0.5% of the tube flow.

 **Note:** In some applications other types of resilient materials are used, such as hypalon, butile or natural rubber. Please contact us if you require one of these materials.

4- PACKING

C.M.O.'s standard packing is composed of three lines with a specially designed EPDM O-ring in the middle which provides watertight integrity between the body and the gate, preventing any type of leakage to the atmosphere. It is located in an easily accessible place and can be replaced without dismantling the valve from the pipeline. Below we indicate various types of packing available according to the application in which the valve is located:

GREASED COTTON (Recommended for hydraulic services)

This packing is composed of braided cotton fibres soaked in grease both inside and out. It is for general use in hydraulic applications in both pumps and valves.

DRY COTTON

This packing is composed of cotton fibres. It is for general use in hydraulic applications with solids.

COTTON + PTFE

This packing is composed of braided cotton fibres soaked in PTFE both inside and out. It is for general use in hydraulic applications in both pumps and valves.

SYNTHETIC + PTFE

This packing is composed of braided synthetic fibres soaked in PTFE both inside and out. It is for general use in hydraulic applications in both pumps and valves and in all types of fluids, especially corrosive ones, including concentrated and oxidising oils. It is also used in liquids with solid particles in suspension.

LUBRICATED PTFE

It is made with PTFE filaments and designed to work at great speed. It is braided with a diagonal system. Suitable for valves and pumps which work with almost all types of fluids, particularly with the most corrosive, such as: oxidant and concentrated oils. It is also used in liquids with solid content.

KNIFE GATE VALVES

A LUG SERIES

GRAPHITE

This packing is composed of high-purity graphite fibres. A diagonal braiding system is used and it is impregnated with graphite and lubricant which helps to reduce porosity and improve operation. It has a wide range of applications as graphite is resistant to steam, water, oils, solvents, alkali and most acids.

CERAMIC FIBRE

This packing is composed of ceramic material fibres. Its main applications are with air or gas at high temperatures and low pressures.

SEAT/SEALS			PACKING			
Material	Max. Temp. (°C)	Applications	Material	P(bar)	Max. Temp. (°C)	pH
Metal/Metal	>250	High temperature/Low sealtightness	Greased cotton	10	100	6-8
EPDM (E)	90 *	Non-mineral oils, acids and water.	Dry cotton (AS)	0,5	100	6-8
Nitrile (N)	90 *	Hydrocarbons, oils and greases	Cotton + PTFE	30	120	6-8
Viton (V)	200	Hydrocarbons and solvents	Synthetic + PTFE	100	-200+270	0-14
Silicone (S)	200	Food Products	Graphite	40	650	0-14
PTFE (T)	250	Resistant to corrosion	Ceramic Fibre	0,3	1400	0-14

NOTE: More details and other materials available to order.

* → EPDM and nitrile: is possible until serving temperature Max.: 120°C under request.

table 2

5- STEM

The stem on the **C.M.O.** valve is made of 18/8 stainless steel. This characteristic provides high resistance and excellent corrosion-resistant properties.

The valve design can be rising stem or non-rising stem. When a rising stem is required for the valve, a stem hood is supplied to protect the stem from contact with dust and dirt, besides keeping it lubricated.

6- PACKING GLAND

The packing gland allows uniform force and pressure to be applied to the gasket to ensure sealtightness. As standard, valves with cast iron body include GJS-500 packing glands, whilst valves with stainless steel body have CF8M packing glands.

7- ACTUATORS

All types of actuators can be supplied, with the advantage that thanks to the **C.M.O.** design they are fully interchangeable. This design allows customers to change the actuators themselves and no extra assembly accessories are required. A design characteristic of **C.M.O.** valves is that all actuators are interchangeable.

Manual:

Handwheel with rising stem
Handwheel with non-rising stem
Chainwheel
Lever
Gears
Others (square nut,...)

Automatic:

Electric actuator
Pneumatic cylinder
Hydraulic cylinder

KNIFE GATE VALVES

A LUG SERIES

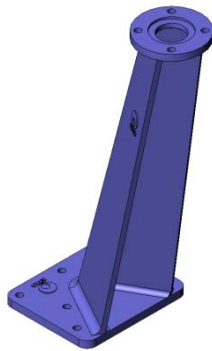

fig. 4

Wide range of accessories available:

- Mechanical stoppers
- Locking devices
- Emergency manual actuators
- Electrovalves
- Positioners
- Limit switches
- Proximity switches
- Straight floor stands (fig. 5)
- Leaning floor stand (fig. 4)

...

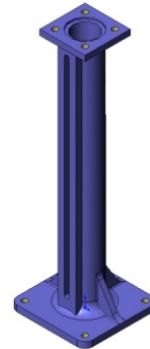

fig. 5

Stem extensions have also been developed, allowing the actuator to be located far away from the valve, to suit all needs. Please consult our technicians beforehand.

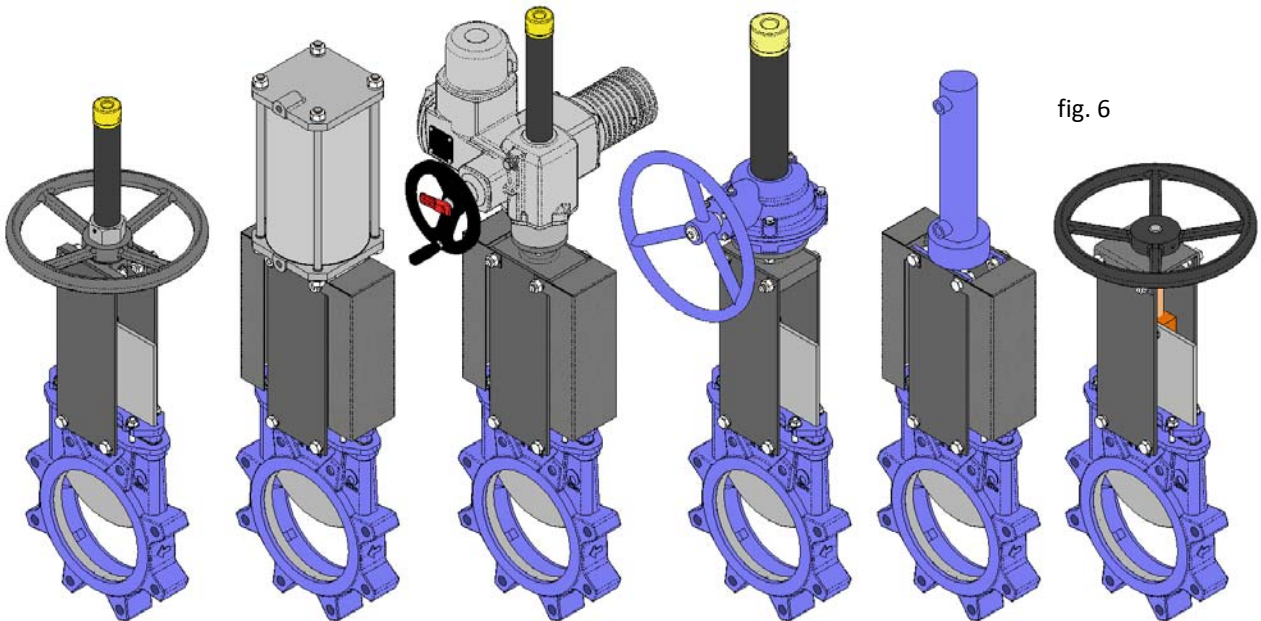

fig. 6

Handwheel with rising stem

Pneumatic actuator

Electric-motor actuator

Geared handwheel

Hydraulic actuator

Handwheel with NON-rising stem

ACCESSORIES AND OPTIONS

Different accessories are available to adapt the valve to specific working conditions such as:

Mirror polished through conduit:

The mirror polished through conduit is especially recommended in the food industry and, as standard, in applications in which solids can stick to the through conduit. It is an alternative to ensure the solids slide off and do not stick to the through conduit.

PTFE lined through conduit:

As with the mirror polished through conduit, it improves the valve's resistance to products that can stick to the through conduit.

C.M.O.

Amategui Aldea 142, 20400 Txarama-Tolosa (SPAIN)

TEC-A LUG.EN08

Tel. Nacional: 902.40.80.50 Fax: 902.40.80.51 / Tel. Internacional: 34.943.67.33.99 Fax: 34.943.67.24.40

cmo@cmo.es <http://www.cmo.es>

page. 6



KNIFE GATE VALVES

A LUG SERIES

Stellited through conduit:

Stellite is added to the through conduit's internal circle to protect it from abrasion.

Scraper in the gasket:

Its function is to clean the through conduit during the opening movement and prevent possible damage to the gasket.

Air injections in the gasket:

By injecting air in the gasket, an air chamber is created which improves the sealtightness.

Cased body:

Recommended in applications in which the fluid can harden and solidify inside the valve's body. An external jacket keeps the body temperature constant, preventing the fluid from solidifying.

Electrovalves (Fig. 7):

For air distribution to pneumatic actuators.

Mechanical limit switches, inductive switches and positioners:

Limit switches or inductive switches are installed to indicate precise valve position, as well as positioners to indicate continuous position (Fig. 7).

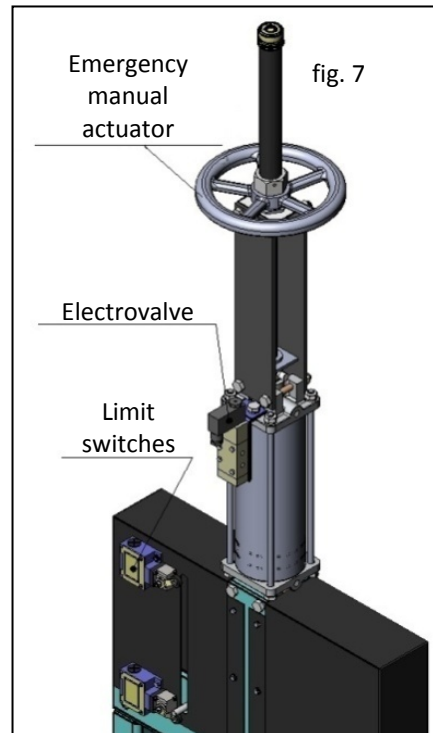

Emergency manual actuator (hand wheel / gear box) (Fig. 7):

Allows manual operation of the valve in the event of power or air failure.

Mechanical locking device:

Allows the valve to be mechanically locked in a set position for long periods.

Stroke limiting mechanical stops:

They allow the stroke to be mechanically adjusted, limiting the valve run.

Holes in the body (Fig. 8):

Several holes are drilled in the body to flush air, steam or other fluids out with the aim of cleaning the valve seat before sealing.

Connection boxes, wiring and pneumatic piping:

Units supplied fully assembled with all the necessary accessories.

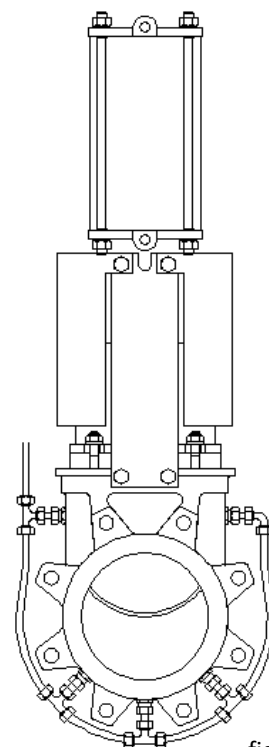

fig. 8



KNIFE GATE VALVES

A LUG SERIES

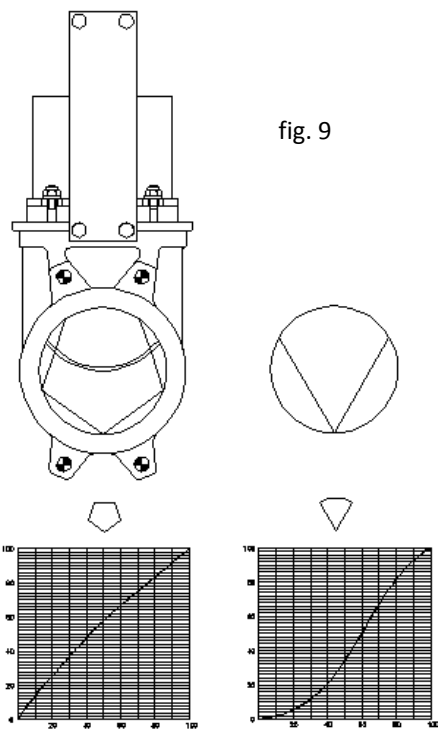

fig. 9

Triangular (V-Notch) and pentagonal diaphragm with indication rule (Fig. 9)

Recommended for applications in which it is necessary to regulate the flow, it allows flow control according to the valve's opening percentage.

VERTICAL: % MAXIMUM FLOW
HORIZONTAL: % OF VALVE OPENING

Interchangeable actuators:

All actuators are easily interchangeable.

Actuator or yoke support

Made of EPOXY-coated steel (or stainless steel to order), its robust design gives it great rigidity in order to resist the most adverse operation conditions.

Epoxy Coating

All cast iron and carbon steel bodies and components on **C.M.O.** valves are EPOXY coated, giving the valves great resistance to corrosion and an excellent finish.

C.M.O.'s standard colour is blue RAL-5015.

Through conduit Safety Protection

In accordance with European Safety Standards ("EC" marking), **C.M.O.** automated valves are equipped with through conduit guards, to prevent any objects from being accidentally caught or dragged in the through conduit.

Bonnet (fig. 10)

Provides total sealtightness to the outside, reducing the packing maintenance required.

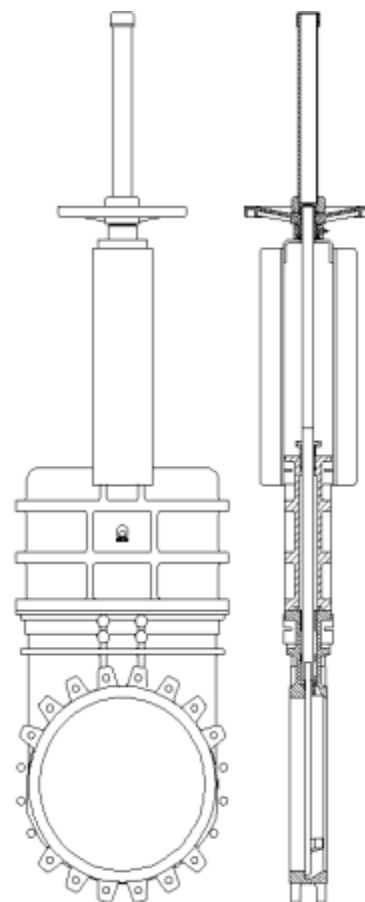

fig. 10

KNIFE GATE VALVES

A LUG SERIES

TYPES OF EXTENSION

When the valve needs to be operated from a distance, the following different types of actuators can be fitted:

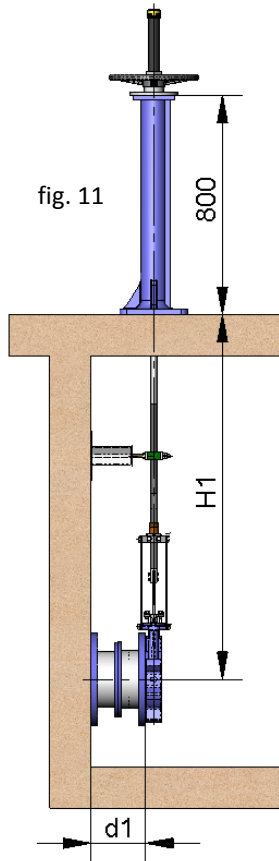

1 - Extension: Floor Stand.

This extension is performed by coupling a spindle to the stem. By defining the length of the spindle, the desired extension is achieved. A floor stand is normally installed to support the actuator.

The definition variables are as follows:

H1: Distance from the valve shaft to the base of the stand.

d1: Separation from the wall to the end of the connecting flange.

Characteristics:

- It can be coupled to any type of actuator.
- A stem support-guide is recommended (fig. 12) every 1.5 m.
- The standard floor stand is 800 mm high (fig. 11). Other floor stand measurements available to order.
- A position indicator can be fitted to determine the valve's percentage of opening.
- Possibility of leaning floor stand (fig. 13).

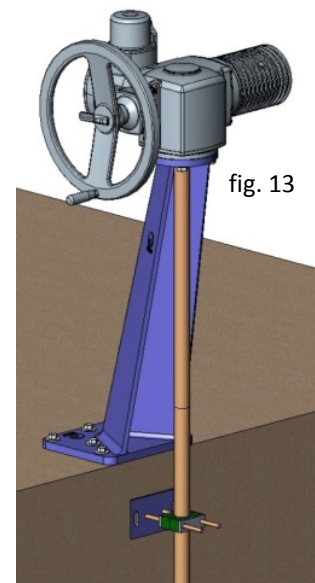
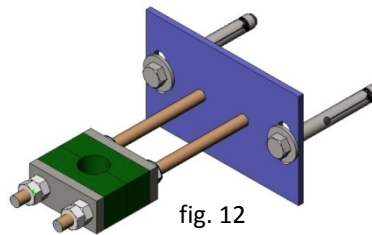

COMPONENTS LIST	
Component	Standard Version
Stem	AISI 303
Stem	AISI 304
Guide-support	Carbon steel with EPOXI coating
Slide	Nylon
Floor Stand	GJS-500 with EPOXY coating

table 3



KNIFE GATE VALVES

A LUG SERIES

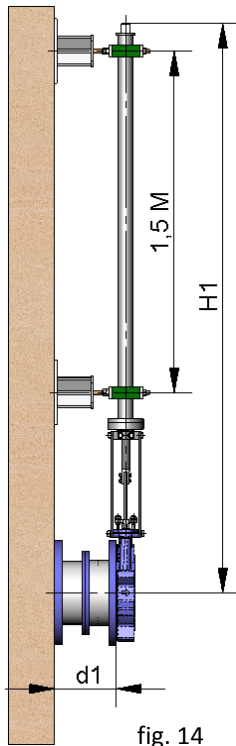

fig. 14

2 - Extension: Pipe (fig. 14)

Consists of raising the actuator. The pipe will rotate with the wheel or key when the valve is operated, although this will always remain at the same height.

The definition variables are as follows:

H1: Distance from the valve shaft to the required height of the actuator.

d1: Separation from the wall to the end of the connecting flange.

Characteristics:

- Standard actuators: Handwheel and "Square Nut".
- A pipe support-guide is recommended every 1.5m.
- The standard materials are: EPOXY coated carbon steel or stainless steel.

3 - Extension: Extended Support Plates (fig. 15)

When a short extension is required, it can be achieved by extending the support plates. An intermediate yoke can be fitted to reinforce the support plates structure.

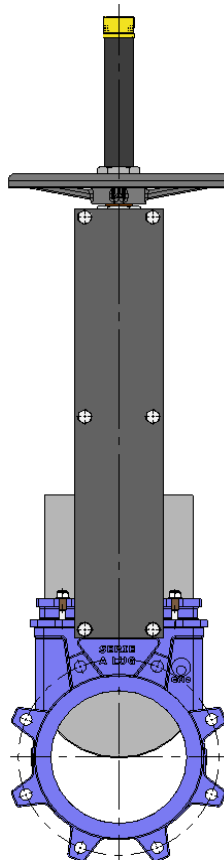

fig. 15

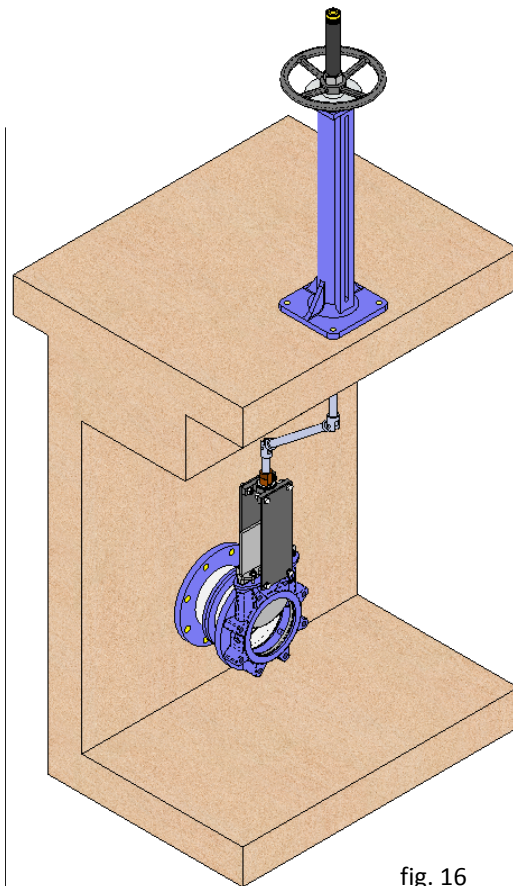

fig. 16

4 - Extension: Cardan joint (Fig. 16)

If the valve and the actuator are not in correct alignment, the problem can be resolved by fitting a universal joint.

KNIFE GATE VALVES

A LUG SERIES

HANDWHEEL with Rising Stem

- **B = max. width** of the valve (without actuator).
- D = max. height** of the valve (without actuator).
- Options:
 - Limiting switches.
 - Extensions: stand, pipe, plates,...
 - DN higher than those shown in the table.
- Actuator comprising:
 - Handwheel.
 - Stem.
 - Nut.
 - Stem protection hood.
- Available: DN50 to DN1200, other DN on request.
- From DN600 the actuator is with gears.

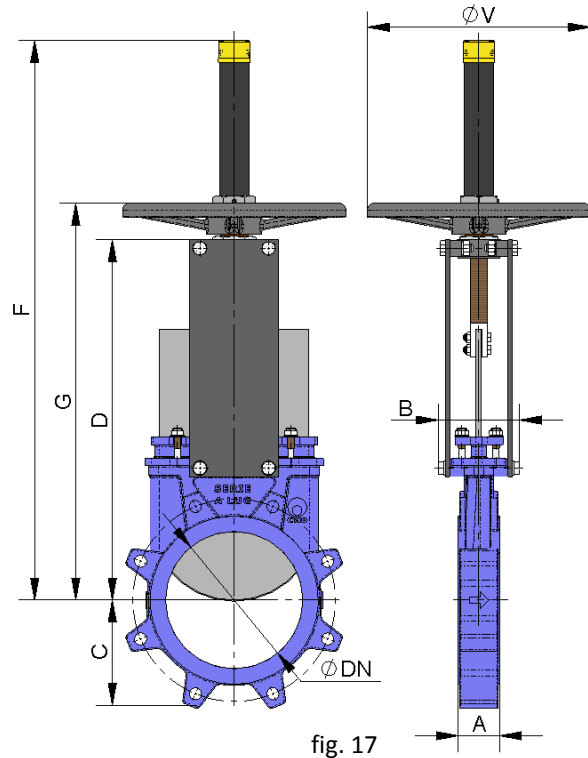

fig. 17

DN	ΔP (Kg/cm ²)	DRAW (Nw)	TORQUE (Nm)	A	B	C	D	F	G	ϕV
50	10	829	2	40	91	61	241	410	280	225
65	10	1399	3	40	91	68	268	437	308	225
80	10	2119	5	50	91	91	294	463	333	225
100	10	3310	8	50	91	104	334	503	373	225
125	10	5171	12	50	101	118	367	586	407	225
150	10	7448	17	60	101	130	419	638	458	225
200	8	10612	30	60	118	159	525	816	578	325
250	6	12456	36	70	118	196	626	1017	679	325
300	6	17962	51	70	118	231	726	1117	779	380
350	5	20406	79	96	290	257	797	1337	906	450
400	5	26707	104	100	290	290	903	1443	1012	450
450	3	20376	79	106	290	312	989	1629	1098	450
500	3	25230	98	110	290	340	1101	1741	1210	450
600	3	36506	142	110	290	398	1307	2047	1416	450
700	2	33288	182	110	320	453	1506	--	--	--
800	2	43788	239	110	320	503	1720	--	--	--
900	2	56064	307	110	320	583	1953	--	--	--
1000	2	69269	379	110	320	613	2137	--	--	--
1200	2	100819	654	150	340	728	2616	--	--	--

table 4

C.M.O.

Amategui Aldea 142, 20400 Txarama-Tolosa (SPAIN)

TEC-A LUG.EN08

Tel. Nacional: 902.40.80.50 Fax: 902.40.80.51 / Tel. Internacional: 34.943.67.33.99 Fax: 34.943.67.24.40

cmo@cmo.es <http://www.cmo.es>

page. 11

KNIFE GATE VALVES

A LUG SERIES

HANDWHEEL with Non-Rising Stem

- Suitable when no size limitations exist.
- **B = max. width** of the valve (without actuator).
D = max. height of the valve (no actuator).
- Options:
 - Square nut.
 - Limiting switches.
 - Extensions: stand, pipe, plates,...
 - DN higher than those shown in the table.
- Actuator including:
 - Handwheel.
 - Stem.
 - Guide bushing on the yoke.
 - Nut.
- Available: DN50 to DN1200, other DN on request.
- From DN600 the actuator is with gears.

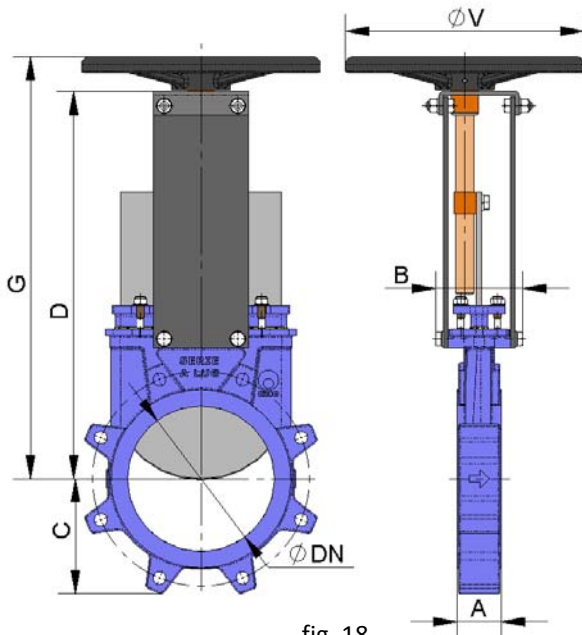

fig. 18

DN	ΔP (Kg/cm ²)	DRAW (Nw)	TORQUE (Nm)	A	B	C	D	G	$\varnothing V$
50	10	829	2	40	91	61	241	280	225
65	10	1399	3	40	91	68	268	308	225
80	10	2119	5	50	91	91	294	333	225
100	10	3310	8	50	91	104	334	373	225
125	10	5171	12	50	101	118	367	407	225
150	10	7448	17	60	101	130	419	458	225
200	8	10612	30	60	118	159	525	578	325
250	6	12456	36	70	118	196	626	679	325
300	6	17962	51	70	118	231	726	779	380
350	5	20406	79	96	290	257	797	906	450
400	5	26707	104	100	290	290	903	1012	450
450	3	20376	79	106	290	312	989	1098	450
500	3	25230	98	110	290	340	1101	1210	450
600	3	36506	142	110	290	398	1307	1416	450
700	2	33288	182	110	320	453	1506	--	--
800	2	43788	239	110	320	503	1720	--	--
900	2	56064	307	110	320	583	1953	--	--
1000	2	69269	379	110	320	613	2137	--	--
1200	2	100819	654	150	340	728	2616	--	--

table 5

C.M.O.

Amategui Aldea 142, 20400 Txarama-Tolosa (SPAIN)

TEC-A LUG.EN08

Tel. Nacional: 902.40.80.50 Fax: 902.40.80.51 / Tel. Internacional: 34.943.67.33.99 Fax: 34.943.67.24.40

cmo@cmo.es <http://www.cmo.es>

page. 12

KNIFE GATE VALVES

A LUG SERIES

CHAINWHEEL

- Widely used in raised installations with difficult access, the handwheel is fitted in vertical position.

- B = max. width** of the valve (without actuator).
- D = max. height** of the valve (without actuator).

- Options:
 - Limiting switches.
 - Extensions: stand, pipe, plates,...
 - Non-rising stem.
 - DN higher than those shown in the table.

- Including:
 - Handwheel.
 - Stem.
 - Nut.
 - Hood.

Available: DN50 to DN1200, other DN on request.

- From DN600 the actuator is with gears, see * in table.

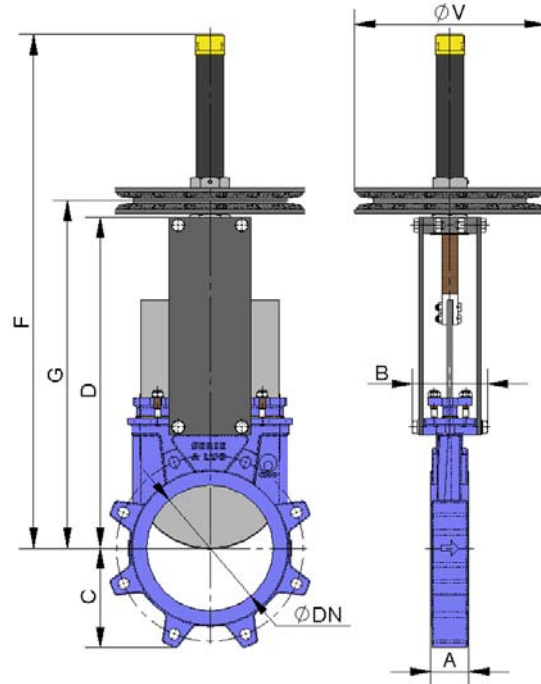

fig. 19

DN	ΔP (Kg/cm ²)	DRAW (Nw)	TORQUE (Nm)	A	B	C	D	F	G	ϕV
50	10	829	2	40	91	61	241	410	280	225
65	10	1399	3	40	91	68	268	437	308	225
80	10	2119	5	50	91	91	294	463	333	225
100	10	3310	8	50	91	104	334	503	373	225
125	10	5171	12	50	101	118	367	586	407	225
150	10	7448	17	60	101	130	419	638	458	225
200	8	10612	30	60	118	159	525	816	578	300
250	6	12456	36	70	118	196	626	1017	679	300
300	6	17962	51	70	118	231	726	1117	779	300
350	5	20406	79	96	290	257	797	1337	906	402
400	5	26707	104	100	290	290	903	1443	1012	402
450	3	20376	79	106	290	312	989	1629	1098	402
500	3	25230	98	110	290	340	1101	1741	1210	402
600	3	36506	142	110	290	398	1307	2047	1416	402
700	2	33288	182*	110	320	453	1506	2406	1658	402*
800	2	43788	239*	110	320	503	1720	2790	1905	402*
900	2	56064	307*	110	320	583	1953	3130	2115	402*
1000	2	69269	379*	110	320	613	2137	3440	2310	402*
1200	2	100819	654*	150	340	728	2616	4050	2815	402*

table 6

C.M.O.

Amategui Aldea 142, 20400 Txarama-Tolosa (SPAIN)

TEC-A LUG.EN08

Tel. Nacional: 902.40.80.50 Fax: 902.40.80.51 / Tel. Internacional: 34.943.67.33.99 Fax: 34.943.67.24.40

cmo@cmo.es <http://www.cmo.es>

page. 13



KNIFE GATE VALVES

A LUG SERIES

LEVER

- It is a fast actuator.
- **B = max. width** of the valve (without actuator).
- **D = max. height** of the valve (without actuator).
- The actuator includes:
 - Lever.
 - Rod.
 - Guide bearing.
- Limiting switches to maintain position.
- Available: DN50 to DN300, other DN on request.

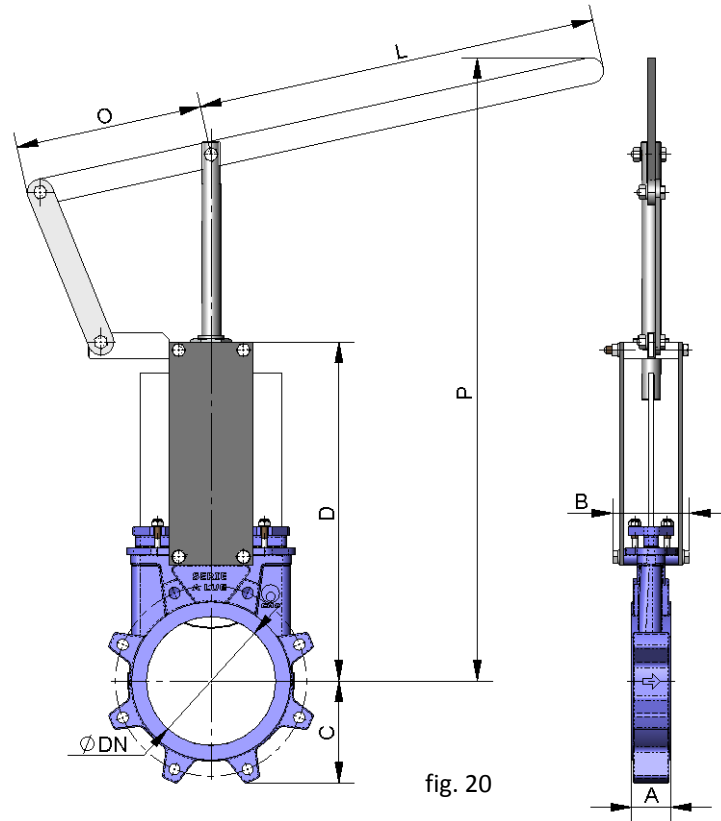

DN	ΔP (Kg/cm ²)	DRAW (Nw)	A	B	C	D	L	O	P
50	10	829	40	91	61	241	325	155	504
65	10	1399	40	91	68	268	325	155	526
80	10	2119	50	91	91	294	325	155	549
100	10	3310	50	91	104	334	325	155	605
125	10	5171	50	101	118	367	425	155	902
150	10	7448	60	101	130	419	425	155	956
200	8	10612	60	118	159	525	620	290	1027
250	6	12456	70	118	196	626	620	290	1416
300	6	17962	70	118	231	726	620	290	1525

table 7

KNIFE GATE VALVES

A LUG SERIES

GEAR BOX

- It is recommendable for DN greater than 600.
- **B = max. width** of the valve (without actuator).
D = max. height of the valve (without actuator).
- Options:
 - Chainwheel.
 - Limiting switches.
 - Extensions: stand, pipe, plates,...
 - Non-rising stem.
- Actuator comprising:
 - Stem.
 - Yoke.
 - Cone-shaped gear box.
 - Handwheel.
- Standard reduction ratio = 4 to 1.
- Available: DN 50 to DN 2000, other DN on request.

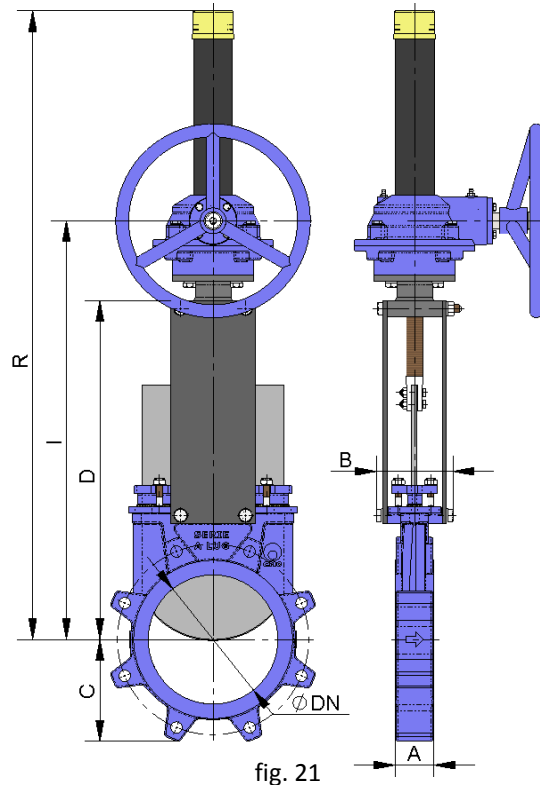

fig. 21

DN	ΔP (Kg/cm ²)	DRAW (Nw)	TORQUE (Nm)	A	B	C	D	I	R
50	10	829	2	40	91	61	241	365	537
65	10	1399	3	40	91	68	268	392	564
80	10	2119	5	50	91	91	294	418	590
100	10	3310	8	50	91	104	334	458	630
125	10	5171	12	50	101	118	367	491	663
150	10	7448	17	60	101	130	419	543	715
200	8	10612	30	60	118	158	525	649	943
250	6	12456	36	70	118	196	616	740	1033
300	6	17962	51	70	118	230	704	828	1121
350	5	20406	79	96	290	247	767	891	1305
400	5	26707	104	100	290	290	865	989	1403
450	3	20376	79	106	290	304	989	1113	1677
500	3	25230	98	110	290	340	1101	1225	1788
600	3	36506	142	110	290	398	1307	1428	1995
700	2	33288	182	110	320	453	1506	1658	2401
800	2	43788	239	110	320	503	1720	1872	2715
900	2	56064	307	110	320	583	1953	2105	3043
1000	2	69269	379	110	320	613	2137	2290	3351
1200	2	100819	654	150	340	728	2616	2802	4042
1400	2	137297	891	150	390	837	3250	3415	4852
1500	2	159330	1034	170	426	890	3517	3675	5217
1600	2	181408	1362	170	426	957	3775	3945	5575
1800	2	232230	1952	190	440	1057	4242	4415	6242
2000	2	286596	2409	210	480	1162	4540	4720	6740

table 8

C.M.O.

Amategui Aldea 142, 20400 Txarama-Tolosa (SPAIN)

TEC-A LUG.EN08

Tel. Nacional: 902.40.80.50 Fax: 902.40.80.51 / Tel. Internacional: 34.943.67.33.99 Fax: 34.943.67.24.40

cmo@cmo.es <http://www.cmo.es>

page. 15



KNIFE GATE VALVES

A LUG SERIES

DOUBLE-ACTING PNEUMATIC CYLINDER

- The air supply pressure to the pneumatic cylinder is a minimum of 6 Kg/cm² and a maximum of 10 Kg/cm², the air must be dry and lubricated.
- 10 Kg/cm² is the maximum admissible air pressure. For air pressures below 6 Kg/cm², please consult to **C.M.O.**
- For DN50 to DN200 valves, the cylinder's jacket and covers are made of aluminium, the rod of AISI304, the piston of rubber-coated steel and the O-ring seals are made of nitrile.
- For valves larger than DN200 the covers are made of nodular cast iron or carbon steel.
- On request, we can also supply the actuator made entirely of stainless steel, especially for installation in corrosive atmospheres.
- **B = max. width** of the valve (without actuator).
D = max. height of the valve (without actuator).
- Available: DN50 to DN1200, other DN on request.

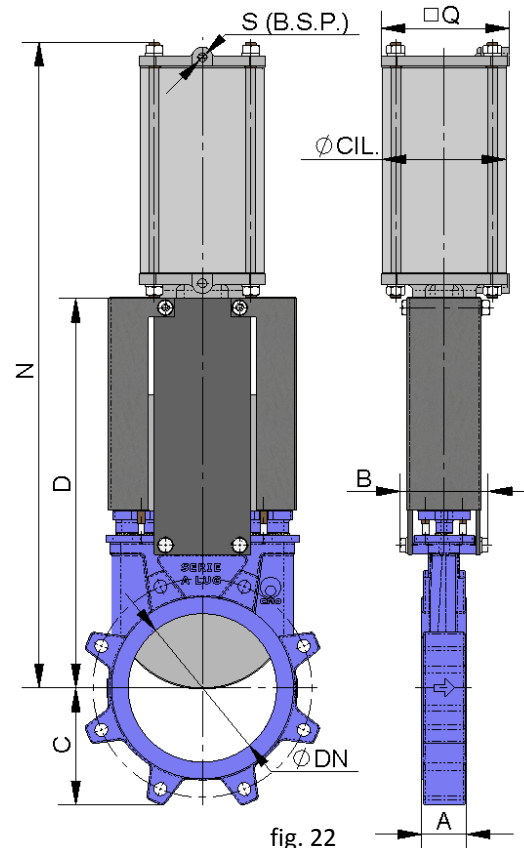

fig. 22

DN	ΔP (Kg/cm ²)	DRAW (Nw)	A	B	C	D	N	Q	Ø CYL.	Ø STEM	S (B.S.P.)
50	10	829	40	91	61	241	416	90	80	20	1/4"
65	10	1399	40	91	68	268	456	90	80	20	1/4"
80	10	2119	50	91	91	294	498	90	80	20	1/4"
100	10	3310	50	91	104	334	562	110	100	20	1/4"
125	10	5171	50	101	118	367	636	135	125	25	1/4"
150	10	7448	60	101	130	419	717	135	125	25	1/4"
200	8	10612	60	118	158	525	874	170	160	30	1/4"
250	6	12456	70	118	196	616	1036	215	200	30	3/8"
300	6	17962	70	118	230	704	1182	215	200	30	3/8"
350	5	20406	96	290	247	767	1381	270	250	40	3/8"
400	5	26707	100	290	290	865	1530	270	250	40	3/8"
450	3	20376	106	290	304	989	1676	382	300	45	1/2"
500	3	25230	110	290	340	1101	1839	382	300	45	1/2"
600	3	36506	110	290	398	1307	2146	382	300	45	1/2"
700	2	33288	110	320	453	1506	2481	444	350	45	1/2"
800	2	43788	110	320	503	1720	2798	444	350	45	1/2"
900	2	56064	110	320	583	1953	3167	508	400	50	1/2"
1000	*	*	110	320	613	2137	3451	508	400	50	1/2"
1200	*	*	150	203	340	728	4135	508	400	50	1/2"

* → Consult

table 9

C.M.O.

Amategui Aldea 142, 20400 Txarama-Tolosa (SPAIN)

TEC-A LUG.EN08

Tel. Nacional: 902.40.80.50 Fax: 902.40.80.51 / Tel. Internacional: 34.943.67.33.99 Fax: 34.943.67.24.40

cmo@cmo.es <http://www.cmo.es>

page. 16

KNIFE GATE VALVES

A LUG SERIES

SINGLE-ACTING PNEUMATIC CYLINDER

- The air supply pressure to the pneumatic cylinder is a minimum of 6 Kg/cm² and a maximum of 10 Kg/cm², the air must be dry and lubricated.
- 10 Kg/cm² is the maximum admissible air pressure. For air pressures below 6 Kg/cm², please consult to **C.M.O.**
- Available for opening or closing in case of air supply failure (spring opening or closing).
- The jacket is made of aluminium, the covers of nodular cast iron or carbon steel, the rod of AISI304, the piston of rubber-coated steel, the O-ring seals of nitrile and the spring is made of steel.
- The **actuator design is spring activated** for valves with diameters **up to DN300**. For larger diameters the actuator contains a double-acting cylinder and an air tank which stores the volume of air necessary to perform the last movement in the event of an air supply failure.
- **B = max. width** of the valve (without actuator).
D = max. height of the valve (without actuator).
- Available: DN50 to DN300, other DN on request.

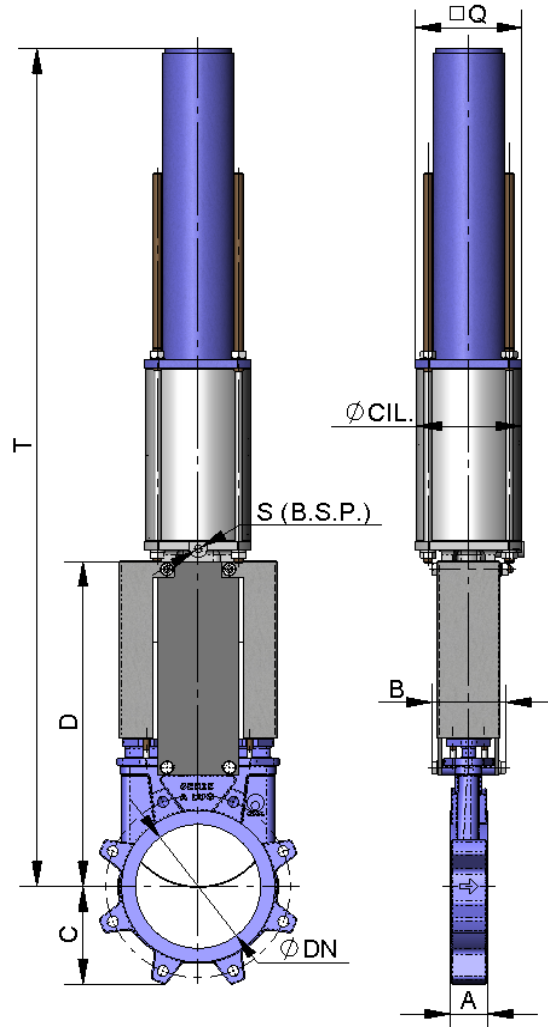

fig. 23

DN	ΔP (Kg/cm ²)	DRAW (Nw)	A	B	C	D	Q	T	ϕ CYL.	S (B.S.P.)	ϕ STEM
50	10	829	40	91	61	241	135	781	125	1/4"	25
65	10	1399	40	91	68	268	135	806	125	1/4"	25
80	10	2119	50	91	91	294	135	833	125	1/4"	25
100	10	3310	50	91	104	334	135	873	125	1/4"	25
125	10	5171	50	101	118	367	170	910	160	1/4"	30
150	10	7448	60	101	130	419	170	961	160	1/4"	30
200	8	10612	60	118	158	525	215	1357	200	3/8"	30
250	6	12456	70	118	196	616	270	1845	250	3/8"	40
300	6	17962	70	118	230	704	270	2005	250	3/8"	40

table 10

C.M.O.

Amategui Aldea 142, 20400 Txarama-Tolosa (SPAIN)

TEC-A LUG.EN08

Tel. Nacional: 902.40.80.50 Fax: 902.40.80.51 / Tel. Internacional: 34.943.67.33.99 Fax: 34.943.67.24.40

cmo@cmo.es <http://www.cmo.es>

page. 17



KNIFE GATE VALVES

A LUG SERIES

ELECTRIC ACTUATOR

- This actuator is automatic and includes the following parts:
 - Electric motor.
 - Stem.
 - Yoke.
- The electric motor includes:
 - Emergency manual handwheel.
 - Limit switches.
 - Torque limiters.
- Options:
 - Different types and brands.
 - Non-rising stem.
- ISO 5210 / DIN 3338 Flanges.
- Available: DN50 to DN2000, other DN to order.
- From DN500 the motor is assisted with a gear box.

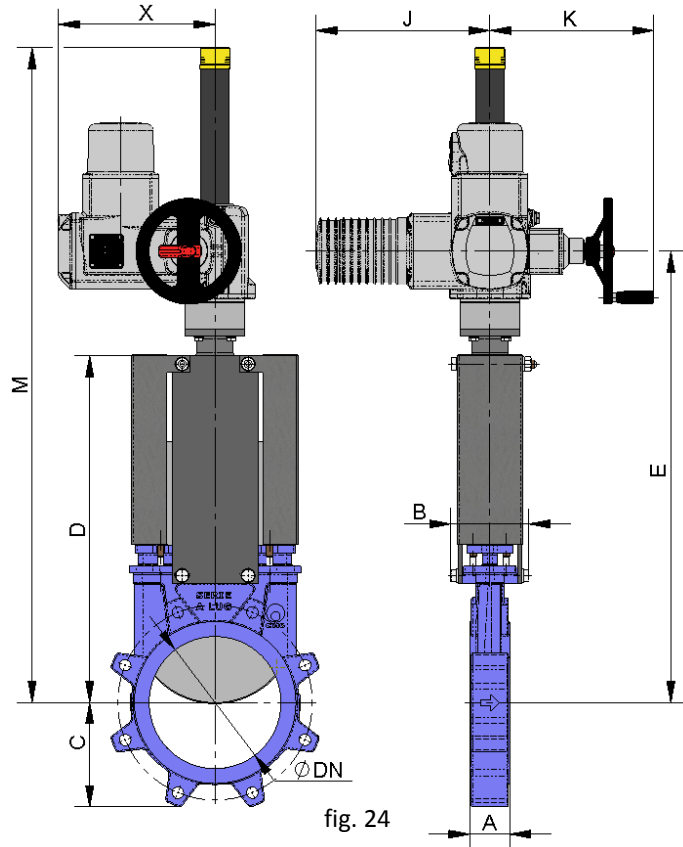

DN	ΔP (Kg/cm ²)	DRAW (Nw)	TORQUE (Nm)	A	B	C	D	E	J	K	M	X
50	10	829	2	40	91	61	241	401	265	249	585	238
65	10	1399	3	40	91	68	268	427	265	249	610	238
80	10	2119	5	50	91	91	294	453	265	249	635	238
100	10	3310	8	50	91	104	334	495	265	249	675	238
125	10	5171	12	50	101	118	367	525	265	249	705	238
150	10	7448	17	60	101	130	419	580	265	249	760	238
200	8	10612	30	60	118	158	525	685	265	249	990	238
250	6	12456	36	70	118	196	616	785	265	249	1090	238
300	6	17962	51	70	118	230	704	885	265	249	1190	238
350	5	20406	79	96	290	247	767	940	283	254	1305	248
400	5	26707	104	100	290	290	865	1045	283	254	1460	248
450	3	20376	79	106	290	304	989	1175	283	254	1755	248
500	3	25230	98	110	290	340	1101	1290	283	254	1870	248
600	3	36506	142	110	290	398	1307	1470	265	249	1995	422
700	2	33288	182	110	320	453	1506	1700	265	249	2401	422
800	2	43788	239	110	320	503	1720	1925	283	254	2715	425
900	2	56064	307	110	320	583	1953	2155	283	254	3043	425
1000	2	69269	379	110	320	613	2137	2340	283	254	3351	425
1200	2	100819	654	150	340	728	2616	2870	389	336	4042	480
1400	2	137297	891	150	390	837	3250	3485	389	340	4852	480
1500	2	159330	1034	170	426	890	3517	3745	389	340	5217	528
1600	2	181408	1362	170	426	957	3775	4015	389	340	5575	528
1800	2	232230	1952	190	440	1057	4242	4495	430	365	6242	552
2000	2	286596	2409	210	480	1162	4540	4800	430	365	6740	595

table 11

C.M.O.

Amategui Aldea 142, 20400 Txarama-Tolosa (SPAIN)

TEC-A LUG.EN08

Tel. Nacional: 902.40.80.50 Fax: 902.40.80.51 / Tel. Internacional: 34.943.67.33.99 Fax: 34.943.67.24.40

cmo@cmo.es <http://www.cmo.es>

page. 18

KNIFE GATE VALVES

A LUG SERIES

HYDRAULIC ACTUATOR (Oil pressure: 135 Kg/cm²)

- **B = max. width** of the valve (without actuator).
- **D = max. height** of the valve (without actuator).
- The hydraulic actuator includes:
 - Hydraulic cylinder.
 - Yoke.
- Available: DN50 to DN2000.
- Different types and brands available according to customer's requirements.

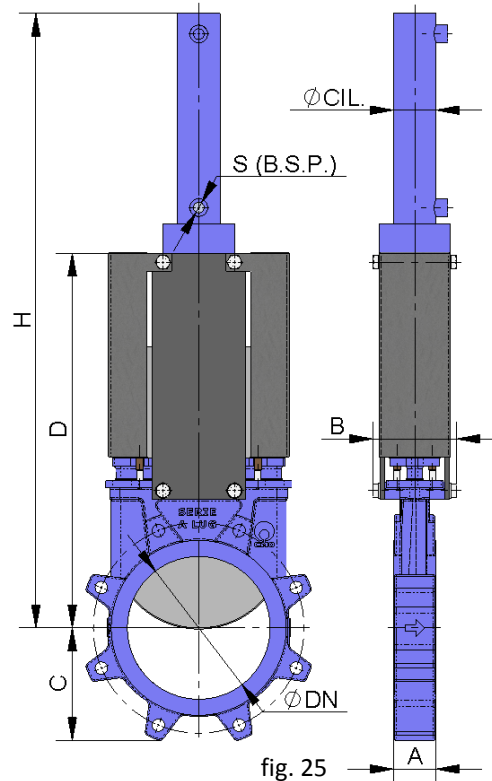

DN	ΔP (Kg/cm ²)	DRAW (Nw)	A	B	C	D	H	Ø CYL.	Ø STEM	S (B.S.P.)	Cap. Oil (dm ³)
50	10	829	40	91	61	241	457	25	18	3/8"	0.03
65	10	1399	40	91	68	268	500	25	18	3/8"	0.03
80	10	2119	50	91	91	294	560	25	18	3/8"	0.04
100	10	3310	50	91	104	334	620	32	22	3/8"	0.09
125	10	5171	50	101	118	367	683	32	22	3/8"	0.11
150	10	7448	60	101	130	419	755	40	28	3/8"	0.20
200	8	10612	60	118	158	525	926	50	28	3/8"	0.42
250	6	12456	70	118	196	616	1077	50	28	3/8"	0.52
300	6	17962	70	118	230	704	1246	50	28	3/8"	0.62
350	5	20406	96	290	247	767	1376	50	28	3/8"	0.73
400	5	26707	100	290	290	865	1532	63	36	3/8"	1.31
450	3	20376	106	290	304	989	1707	63	36	3/8"	1.47
500	3	25230	110	290	340	1101	1869	63	36	3/8"	1.62
600	3	36506	110	290	398	1307	2176	80	45	3/8"	3.12
700	2	33288	110	320	453	1506	2525	80	45	3/8"	3.62
800	2	43788	110	320	503	1720	2839	100	56	1/2"	6.44
900	2	56064	110	320	583	1953	3172	100	56	1/2"	7.25
1000	2	69269	110	320	613	2137	3496	125	70	1/2"	10.25
1200	2	100819	150	340	728	2616	4175	125	70	1/2"	15.05
1400	2	137297	150	390	837	3250	4950	160	70	1/2"	28.65
1500	2	159330	170	426	890	3517	5290	160	70	1/2"	30.7
1600	2	181408	170	426	957	3775	5660	160	70	1/2"	32.7
1800	2	232230	190	440	1057	4242	6325	200	90	1/2"	57.35
2000	2	286596	210	480	1162	4540	6830	200	90	1/2"	63.65

table 12

C.M.O.

Amategui Aldea 142, 20400 Txarama-Tolosa (SPAIN)

TEC-A LUG.EN08

Tel. Nacional: 902.40.80.50 Fax: 902.40.80.51 / Tel. Internacional: 34.943.67.33.99 Fax: 34.943.67.24.40

cmo@cmo.es <http://www.cmo.es>

page. 19

KNIFE GATE VALVES

A LUG SERIES

INFORMATION ON FLANGE DIMENSIONS

EN 1092-2 PN10

ND	ΔP (Kg/cm ²)	Qty. ●	Metric	P	ϕK
50	10	4	M 16	8	125
65	10	4	M 16	8	145
80	10	8	M 16	9	160
100	10	8	M 16	9	180
125	10	8	M 16	9	210
150	10	8	M 20	10	240
200	8	8	M 20	10	295
250	6	12	M 20	12	350
300	6	12	M 20	12	400
350	5	16	M 20	21	460
400	5	16	M 24	21	515
450	3	20	M 24	22	565
500	3	20	M 24	22	620
600	3	20	M 27	22	725
700	2	24	M 27	22	840
800	2	24	M 30	22	950
900	2	28	M 30	20	1050
1000	2	28	M 33	20	1160
1200	2	32	M 36	22	1380
1400	2	36	M 39	26	1590
1500	2	36	M 39	35	1700
1600	2	40	M 45	40	1820
1800	2	44	M 45	40	2020
2000	2	48	M 45	45	2230

table 13

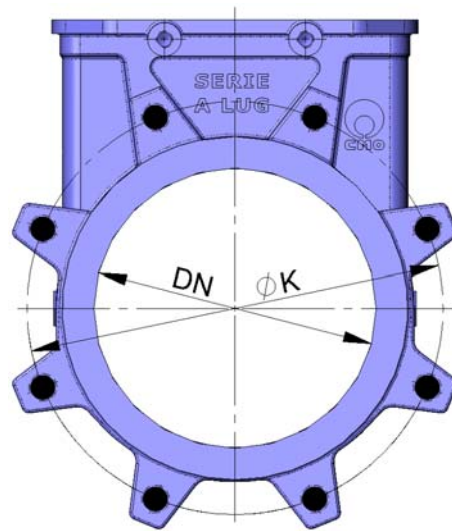

fig. 26

● BLIND TAPPED HOLE

ANSI B16, class 150

ND	ΔP (Kg/cm ²)	Qty. ●	R UNC	P	ϕK
2"	10	4	5/8"	8	120,6
2 1/2"	10	4	5/8"	8	139,7
3"	10	4	5/8"	9	152,4
4"	10	8	5/8"	9	190,5
5"	10	8	3/4"	9	215,9
6"	10	8	3/4"	10	241,3
8"	8	8	3/4"	10	298,4
10"	6	12	7/8"	12	361,9
12"	6	12	7/8"	12	431,8
14"	5	12	1"	21	476,2
16"	5	16	1"	21	539,7
18"	3	16	1 1/8"	22	577,8
20"	3	20	1 1/8"	22	635
24"	3	20	1 1/4"	22	749,3
28"	2	28	1 1/4"	22	863,6
30"	2	28	1 1/4"	22	914,4
32"	2	28	1 1/2"	22	977,9
36"	2	32	1 1/2"	20	1085,9
40"	2	36	1 1/2"	20	1200,2
48"	2	44	1 1/2"	22	1422,4

table 14

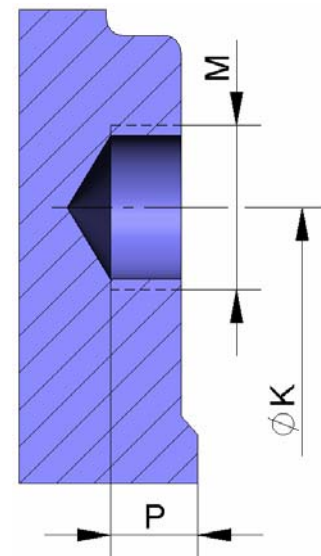

fig. 27

C.M.O.

Amategui Aldea 142, 20400 Txarama-Tolosa (SPAIN)

TEC-A LUG.EN08

Tel. Nacional: 902.40.80.50 Fax: 902.40.80.51 / Tel. Internacional: 34.943.67.33.99 Fax: 34.943.67.24.40

cmo@cmo.es <http://www.cmo.es>

page. 20